

1932 Ford  
Coupe  
no bumpers  
or fenders

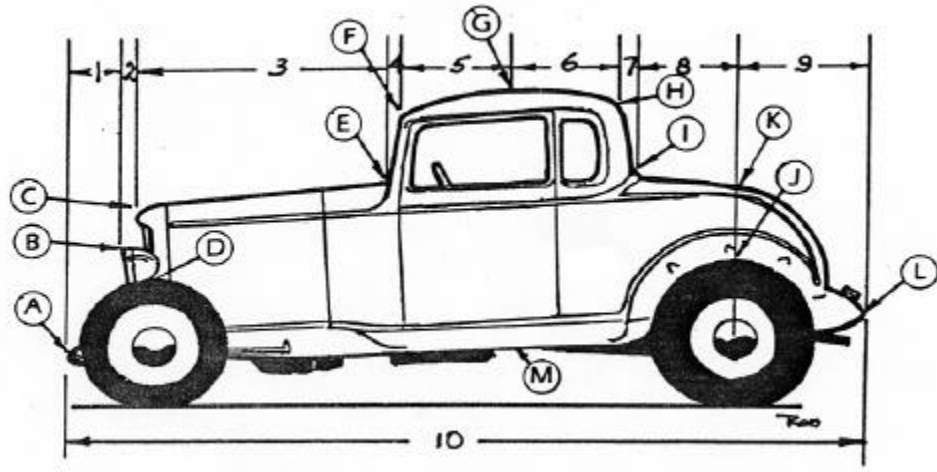

**Lengths - Measured Horizontally**

- # 1 Front of car to front of headlight \_\_\_\_\_
- # 2 Front of headlight to front of hood \_\_\_\_\_
- # 3 Front of hood to base of windshield \_\_\_\_\_
- # 4 Base of windshield to front of roof \_\_\_\_\_
- # 5 Front of roof to highpoint of roof \_\_\_\_\_
- # 6 Highpoint of roof to rear of roof \_\_\_\_\_
- # 7 Rear of roof to base of rear window \_\_\_\_\_
- # 8 Base of window to center of rear axle \_\_\_\_\_
- # 9 Center of rear axle to rear of car \_\_\_\_\_
- # 10 Overall length of car, front to rear \_\_\_\_\_

If you have measured correctly, the sum of # 1 through # 9 should equal # 10.

**Heights - Measured from Ground**

- HA Height at front of car \_\_\_\_\_
- HB Height at top of headlight \_\_\_\_\_
- HC Height at front of hood \_\_\_\_\_
- HD Height at top of front tire \_\_\_\_\_
- HE Height at base of windshield \_\_\_\_\_
- HF Height at front of roof \_\_\_\_\_
- HG Height at highpoint of roof \_\_\_\_\_
- HH Height at rear of roof \_\_\_\_\_
- HI Height at base of rear window \_\_\_\_\_
- HJ Height of rear tire \_\_\_\_\_
- HK Height of trunk at point "K" \_\_\_\_\_
- HL Height at rear of car \_\_\_\_\_
- HM Road clearance \_\_\_\_\_

**Widths, Measured Side to Side at Points Shown**

- WA Width of car at front \_\_\_\_\_
- WB Width of car at top of headlights \_\_\_\_\_
- WC Width of hood at front \_\_\_\_\_
- WD Width of car at front tires \_\_\_\_\_
- WE Width of car at base of windshield \_\_\_\_\_
- WF Width of roof at front \_\_\_\_\_
- WG Width of roof at highpoint \_\_\_\_\_
- WH Width of roof at rear \_\_\_\_\_
- WI Width at base of rear window \_\_\_\_\_
- WJ Width of car at rear tires \_\_\_\_\_
- WK Width of car across trunk at "K" \_\_\_\_\_
- WL Width of car at rear \_\_\_\_\_

**Vehicle Information**

A photo of the vehicle will help us make the pattern. The photo can be returned if requested.

YEAR \_\_\_\_\_ MAKE \_\_\_\_\_

MODEL \_\_\_\_\_ BODY STYLE \_\_\_\_\_

Name \_\_\_\_\_

Daytime phone \_\_\_\_\_

Date of order \_\_\_\_\_

DIMS 178 (3/03)